 AirDesign GmbH www.ad-gliders.com Hohenbergstraße 9 6067 Absam Austria +43 (0)5222 2246 info@ad-gliders.com	
The Sock	
Paragliding harness Gleitschirm-Gurtzeug Silettle parapente	<input type="checkbox"/> S <input type="checkbox"/> M <input type="checkbox"/> L
Taille : Größe : Prod. MY : Prod. MZ : Prod. MA : Serial number : Werk Nr. : N° de série :	<input type="text"/> <input type="text"/> <input type="text"/> <input type="text"/> <input type="text"/> <input type="text"/> <input type="text"/>
Maximum pilot weight : Maximum Pilotengewicht : Poids max. du pilote :	120 kg
Rescue Container Volume : Rettungskontainer Volumen : Volume conteneur secours :	2,5 - 5L
Test Standard : Prüfnorme : Test standard :	EN1651:2018 NTL 2-565-20
Test Center : Prüfstelle : Centre de test :	Air Turquoise S.A. CH-1844 Villeneuve
READ USER MANUAL BEFORE USE! VOR GEBRAUCH BETRIEBSANWEISUNG LESEN! LIRE LE MANUEL AVANT UTILISATION !	
CHANGE CARABINERS EVERY 5 YEARS / 500 HOURS WECHSELN SIE IHRE KARABINER JÄHRE 5 JAHRE / 500 STUNDEN CHANGERS LES MONTRETONS TOUTS LES 5 ANS / 500 HEURES	
Back protector Rückenprotector Protection dorsale	
Air Turquoise S.A. PH_371_2022	



The Sock

Wear it before flight

WELCOME TO AIRDESIGN

Thank you for choosing AirDesign and The Sock.

This harness is the work of a team of pilots, mountaineers, adventurers, hikers, climbers, who love to share their passion with you.

Based in the Alps, we spent hundreds of hours flying this harness during the development process to ensure you will have lot of pleasure using it for your next adventure.

Please read carefully the manual for this harness.

Please register your harness online on our website at <https://ad-gliders.com/product-registration/?lang=en>. Check the website Product registration page for more details.

If you wish, you can enroll for the AirDesign newsletter. Simply provide us with your e-mail address and you will always be up to date with the very latest news from the AirDesign world.

Up to the minute news and information is available on our Facebook page under "AIRDESIGN gliders". Become a fan and you are online with us whenever you login to Facebook.

More information about The Sock can be found on our website:
www.ad-gliders.com

For any further questions, please contact your nearest AirDesign dealer –
<https://ad-gliders.com/dealerlist/?lang=en>

AIRDESIGN GmbH
Rhombergstraße 9,
6067 Absam
AUSTRIA

TABLE OF CONTENT

WELCOME TO AIRDESIGN	1
SAFETY	3
SIZE CHART	3
DISCOVERING YOUR HARNESS	4
GENERAL DESCRIPTION	4
SAFETY ELEMENTS	4
SEAT STRUCTURE.....	4
LARGE VOLUME CONTAINERS	5
INFLIGHT ACCESSIBLE POCKETS.....	5
PREPARATION FOR FLIGHT	6
UNDER SEAT STORAGE.....	6
INFLATING AIRPILLOW	6
BACK CONTAINER	7
NOSE CONTAINER.....	7
COCKPIT.....	8
SOLAR PANEL CONNECTION POINTS	8
CONNECTION TO TOWING EQUIPMENT.....	8
CLIPPING-IN YOUR HARNESS	9
WAIST STRAP	9
POD CLOSING	9
CHEST CROSS STRAPS	10
CONNECTION TO THE PARAGLIDER RISERS.....	10
CONNECTING THE SPEED BAR	10
HARNESS ADJUSTMENTS	11
1: SEAT INCLINATION ADJUSTMENT (THIGH SUPPORT)	11
2, 3, 4 : LEG LENGTH ADJUSTMENT (FOOTPLATE)	12
5: LOWER BACK ADJUSTMENT (LUMBAR STRAPS).....	12
6: UPPER BACK ADJUSTMENT (SHOULDER STRAPS).....	12
7: SPEED BAR ADJUSTMENT	13
<i>Balance Check</i>	13
<i>In flight Adjustment</i>	13
<i>Enjoy your flight!</i>	14
PREPARING YOUR HARNESS (DETAILS)	15
CONNECTION DETAIL (HARNESS- CARABINER ASSEMBLY).....	15
RESCUE INSTALLATION.....	15
<i>Risers' connection</i>	15
<i>Rescue handle connection</i>	16
<i>Container closing</i>	16
<i>Rescue deployment</i>	17
HARNESS PACKING.....	18
COMPOSITION, CARE AND MAINTENANCE	18
ROUTINE INSPECTION	18
PRODUCT REGISTRATION AND GUARANTEE	19
<i>Product registration – Produktregistrierung - Enregistrement de produit</i>	19
RESPECTING NATURE AND ENVIRONMENT	19

SAFETY

The Sock is certified according to the EN 1651 and the NfL 2-565-20 for a maximum pilot weight of 120kg.

As a light harness, it is not advised to perform any acrobatic maneuver.

Towing is permitted providing it's done under professional supervision, with a specific quick release system, connected to the main carabiners, taking care that there is no possible interaction of the towing system with the reserve container.

Please read this manual carefully and thoroughly.

IMPORTANT SAFETY NOTICE

By the purchase of this equipment, you are responsible for being a certified paraglider pilot and you accept all risks inherent with paragliding activities including injury and death. Improper use or misuse of paragliding equipment greatly increases these risks.

Neither AirDesign nor the seller of AirDesign equipment shall be held liable for personal or third party injuries or damages under any circumstances.

If any aspect of the use of our equipment remains unclear, please contact your local paragliding instructor, AirDesign dealer or the AirDesign importer in your country.

SIZE CHART

The choice of your harness size is important. The chart will help you to choose but we recommend that you try the equipment at one of our dealers.

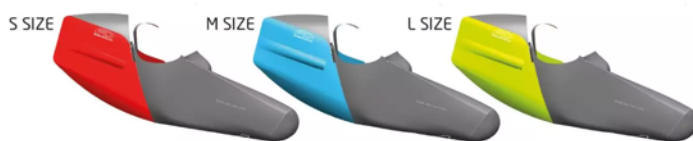

	50 kg	55 kg	60 kg	65 kg	70 kg	75 kg	80 kg	85 kg	90 kg	95 kg	100+ kg*
150cm	S	S	S	S							
155cm	S	S	S	S	S						
160cm	S	S	S	S	S	S	S/M				
165cm	S	S	S	S	S/M	S/M	M	M			
170cm	S	S	S/M	S/M	M	M	M	M	M		
175cm		M	M	M	M	M	M	M/L	M/L	L	
180cm			M	M	M/L	M/L	M/L	L	L	L	L
185cm				M/L	L	L	L	L	L	L	L
190cm					L	L	L	L	L	L	L
195cm						L	L	L	L	L	L
200cm							L	L	L	L	L

* Maximum equipped pilot weight 120kg

DISCOVERING YOUR HARNESS

General description

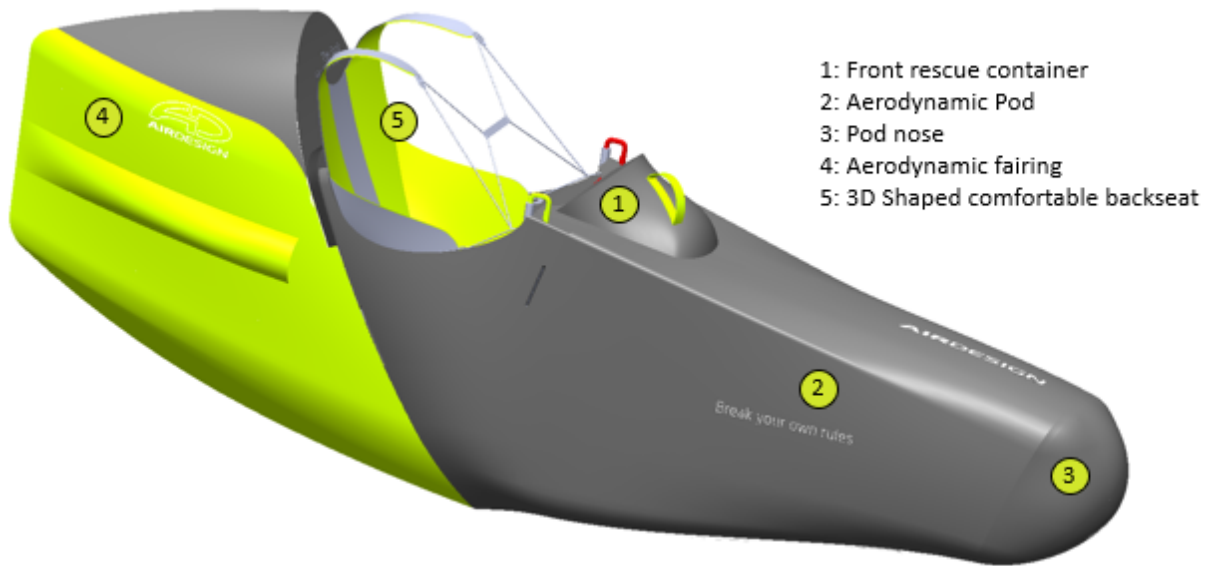

Safety elements

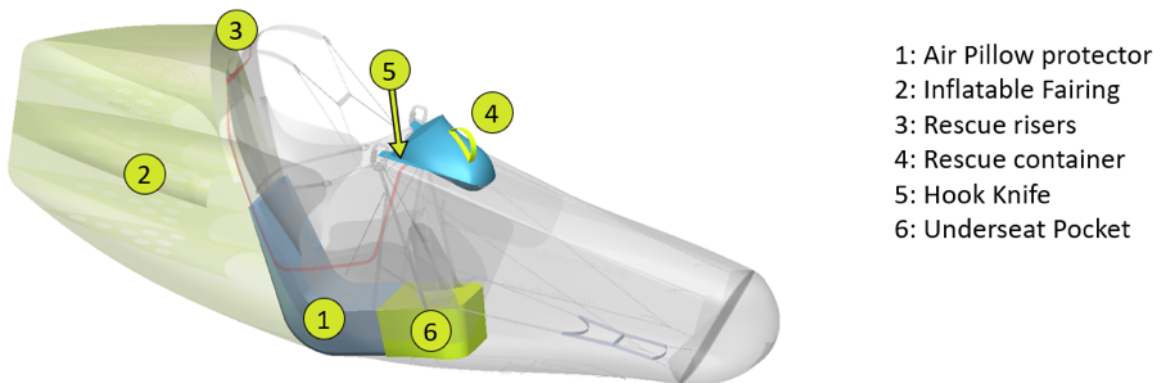

Seat structure

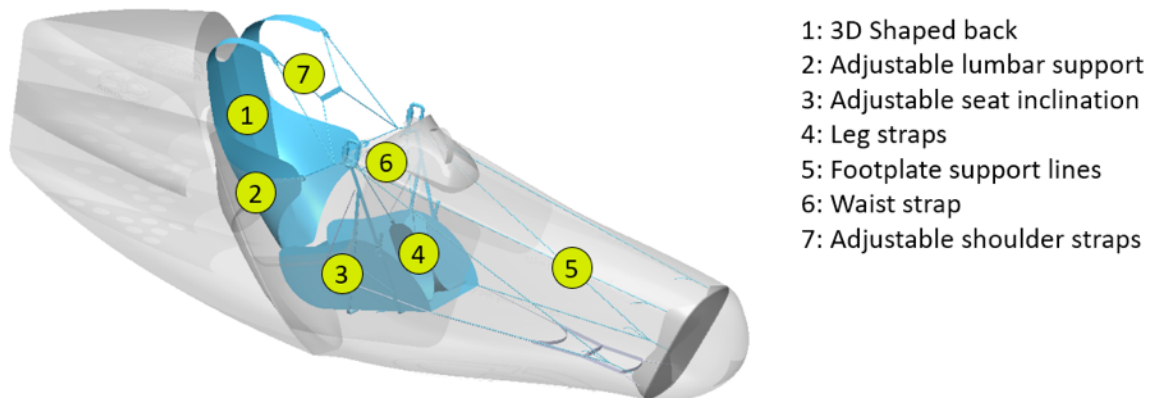

Large volume containers

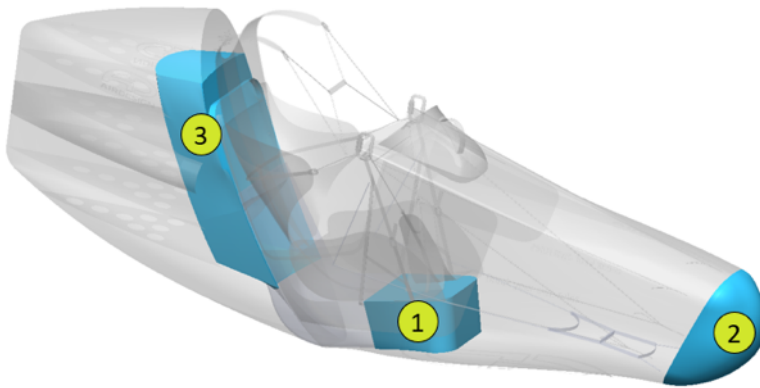

- 1: Underseat container
- 2: Pod Nose Pocket
- 3: Back container (40l)

Inflight accessible pockets

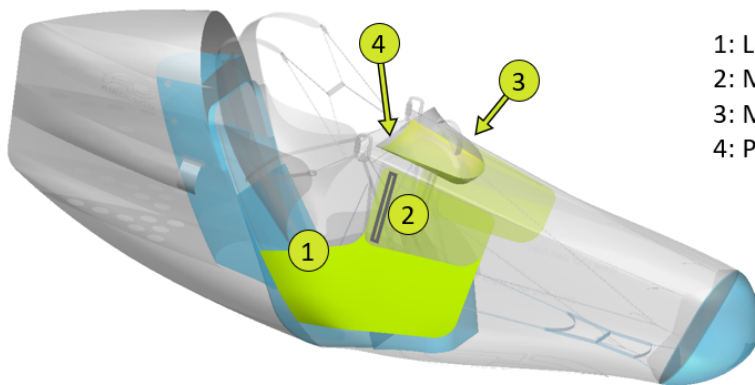

- 1: Large pocket (right)
- 2: Mid-size zipped pocket (right)
- 3: Mid-size zipped pocket (left)
- 4: Power/Food pocket (under rescue)

PREPARATION FOR FLIGHT

The Sock Wear it before flight

Under seat storage

We recommend using the under seat container to store your folded rucksack. This allows to improve your protection with a small additional absorber.

(Certification does not take the bag in consideration but better results were verified)

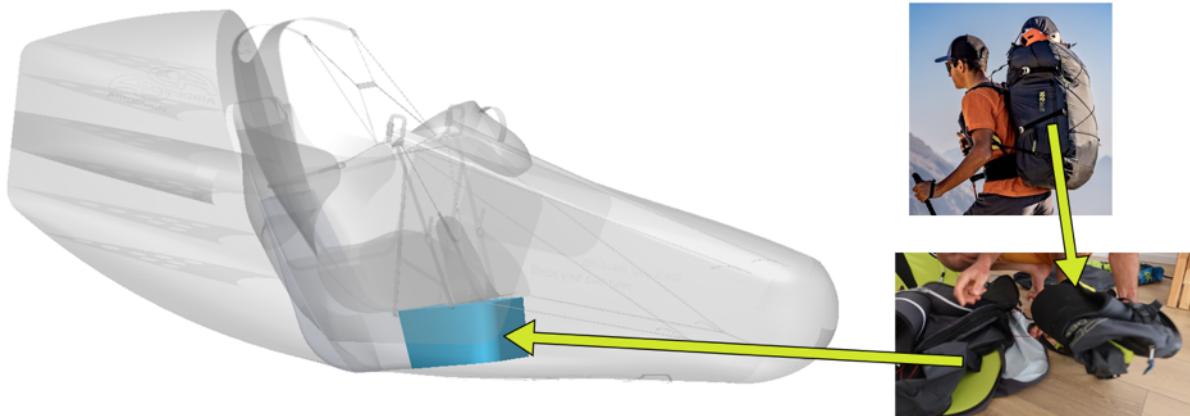

Inflating AirPillow

The Sock harness contains an inflatable AirPillow protector which provides an excellent impact absorption. This protection is EN/LTF and CE certified (Reference : PH_371_2022)

Before using your harness, you need to inflate the AirPillow. You can use the Sock Bag to inflate it using the pipe. Once the Air Pillow is completely filled up, close the pipe using the clamp to lock it tight.



Back container

The back container offers a large storage volume.

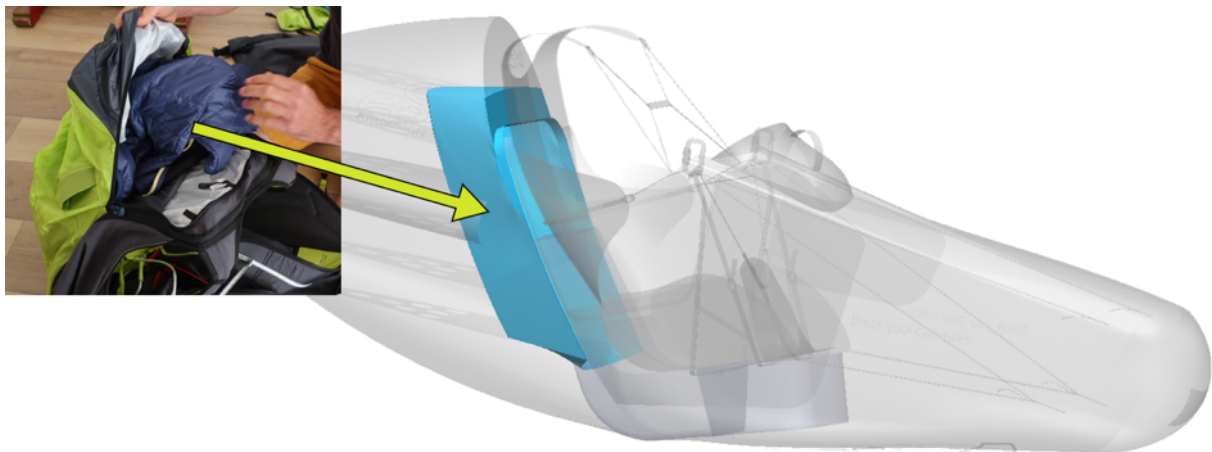

Hydration system hooking and slots:

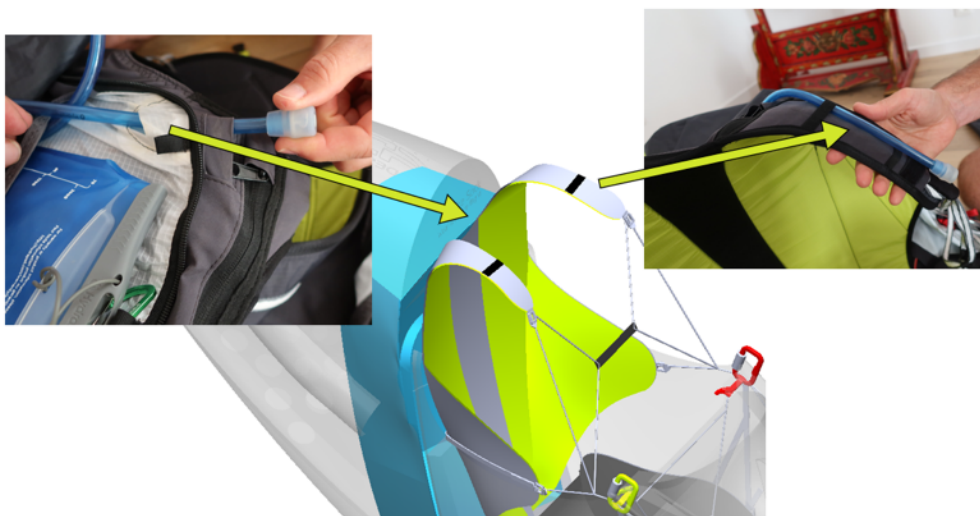

Nose container

You can use the Nose container for your Sock Bag and AirPack.



Warning: Avoid storing heavy objects in this pocket.

Cockpit

The Cockpit is covered with Velcro and allows you to display all your instruments. The Mesh pocket underneath is perfect for all kinds of energy reserves (batteries, power bars). Furthermore, The Sock is delivered with a Hook-Knife and leash – for emergency.

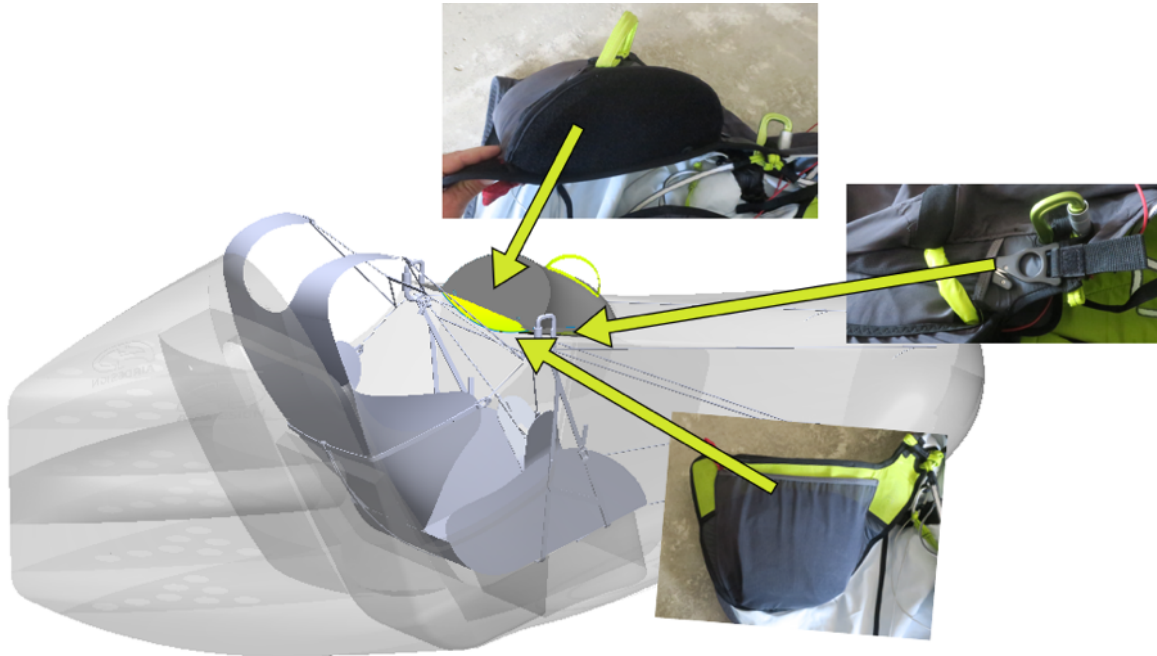

Solar Panel connection points

Loops on the pod allow you to connect and secure foldable solar panels.

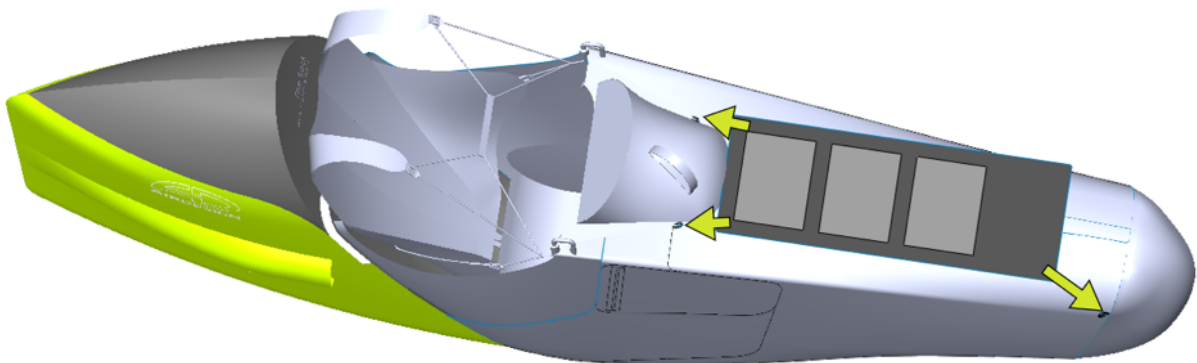

Connection to Towing equipment

The sock Harness is suitable for winch-towing launches. There are no special attachments for this type of launch. The tow release system is to be connected to the main carabiners.

Please ensure that the tow release equipment is compatible with the front rescue container.

Follow the instructions of the tow release and the tow adapter or ask a flight instructor or professional experienced with paraglider towing.

CLIPPING-IN YOUR HARNESS

Waist strap

First get into the harness by putting the shoulders on.
Make sure that the leg loops, coming from behind, pass between your legs.
Then close the waist strap with the toggles and the loops – Red to Red & Green to Green

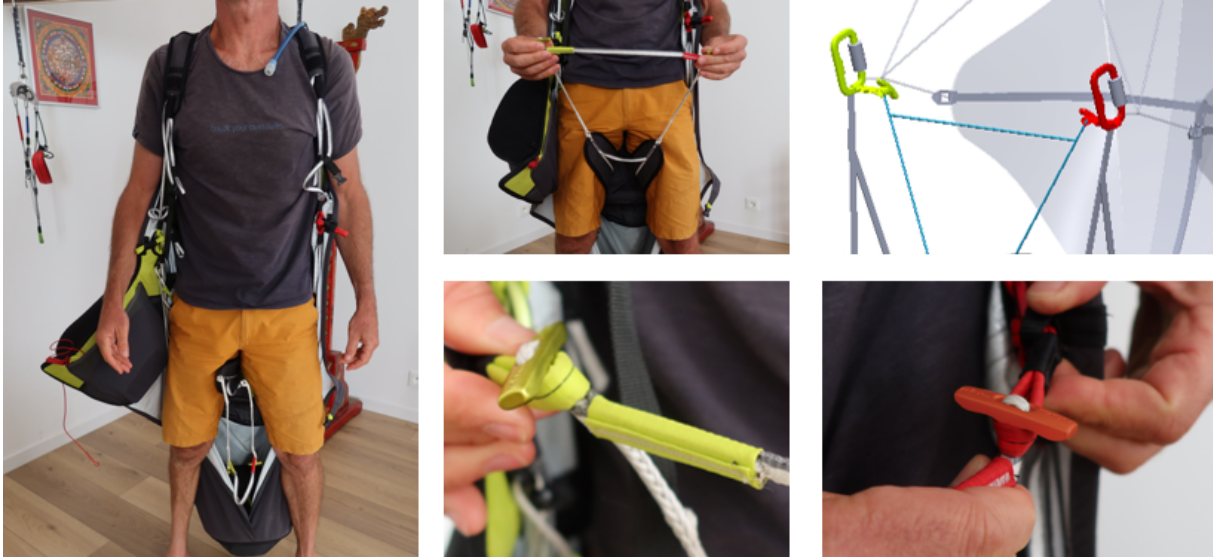

Pod closing

First close the left panel diagonally using the clip on the right side. **Green to Green.**
Make sure the connection is free and nothing is tangled with other lines from the pod.



Then close the right panel passing the rescue container loop around the left red toggle. **Red to Red.**

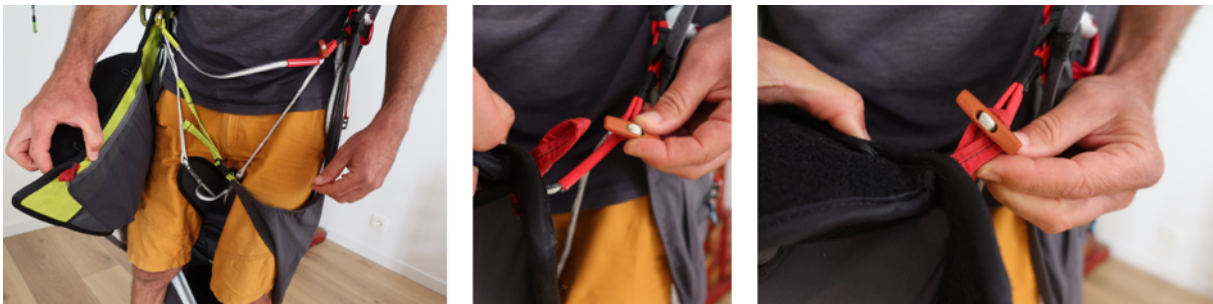

Chest cross straps

Close chest strap using the clip.

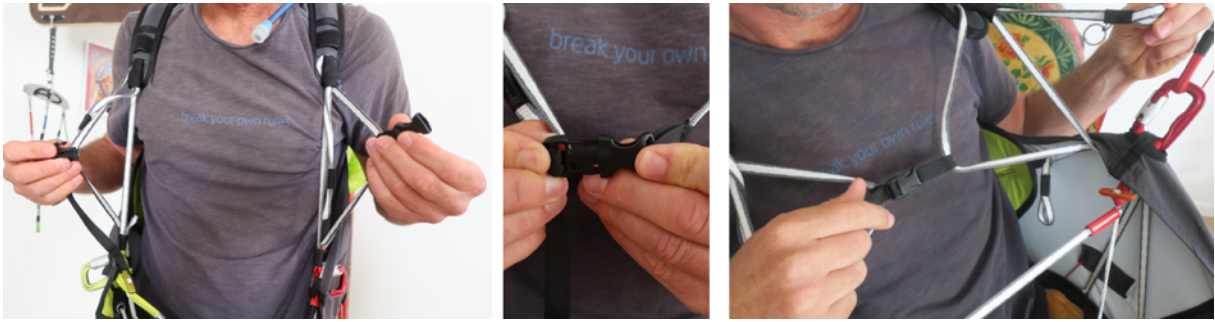

Connection to the paraglider risers



Warning! Ensure that carabiners are locked and not twisted before take-off.

Connecting the speed bar

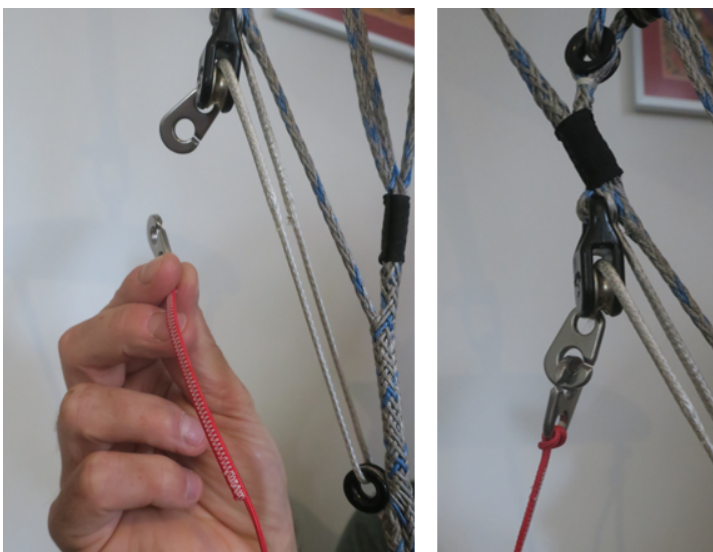

HARNESS ADJUSTMENTS

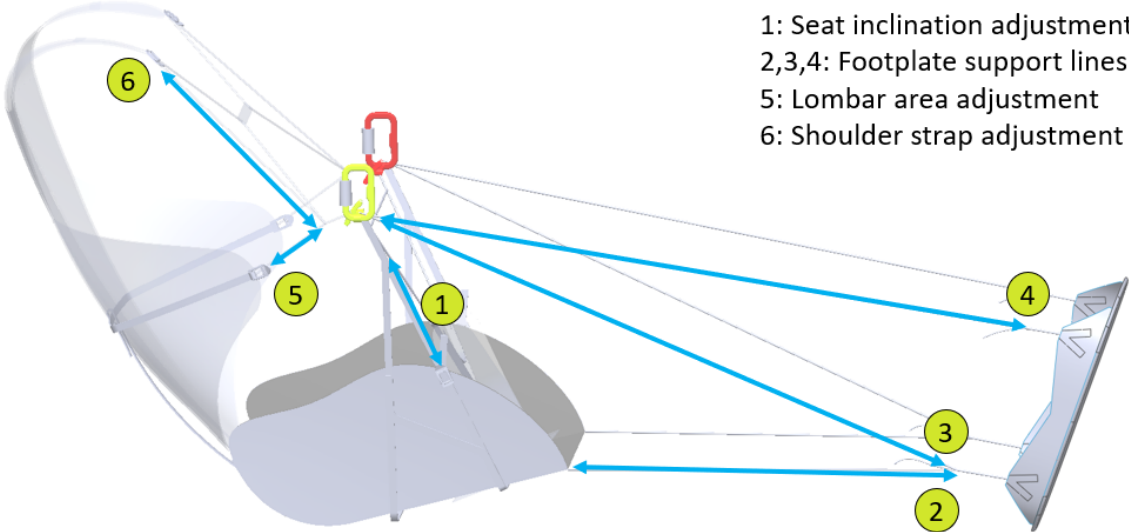

1: Seat Inclination adjustment (thigh support)

Adjust the strap height to reach a comfortable thigh support and inclination.

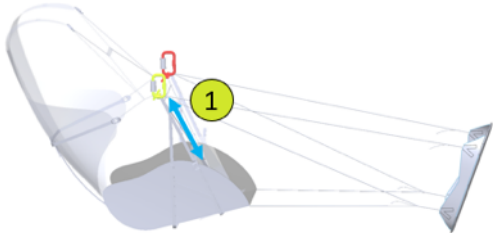

2, 3, 4 : Leg length adjustment (Footplate)

Adjust line lengths by positioning the lark's head knot according to your legs length. Harness is optimized so that all connections are on same knot position (for instance, if line #2 is on knot #1, lines 3 and 4 should also be on knots # 1).

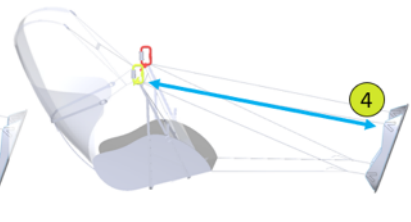
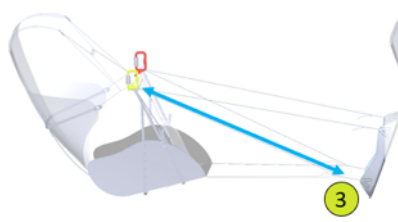
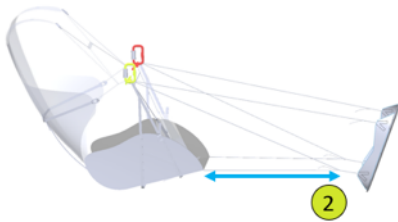
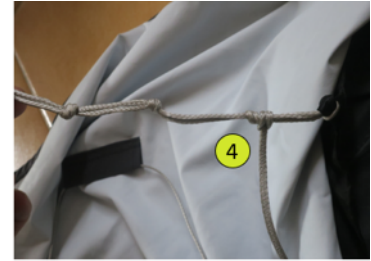
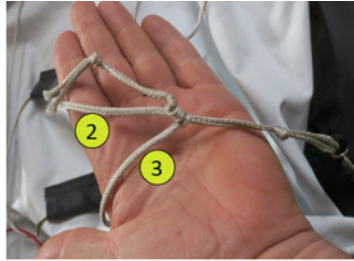

5: Lower back adjustment (Lumbar straps)

Adjust the lumbar straps symmetrically for a comfortable fit and balanced back support.

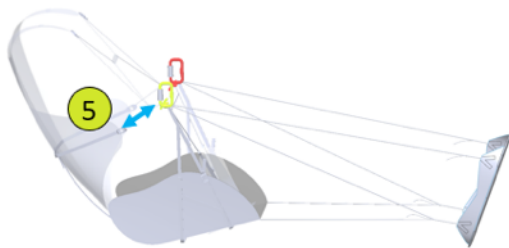

6: Upper back adjustment (Shoulder straps)

Adjust the shoulders symmetrically for a balanced back support.

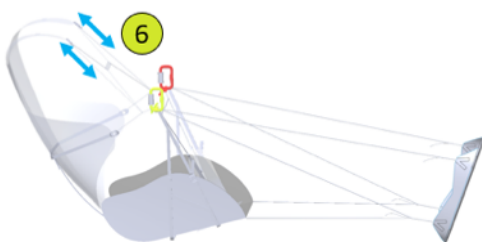

7: Speed bar adjustment

Speed bar is already mounted with a standard adjustment.

Should you need to adjust the speed bar line length, use the knots at bottom of the speed bar lines.

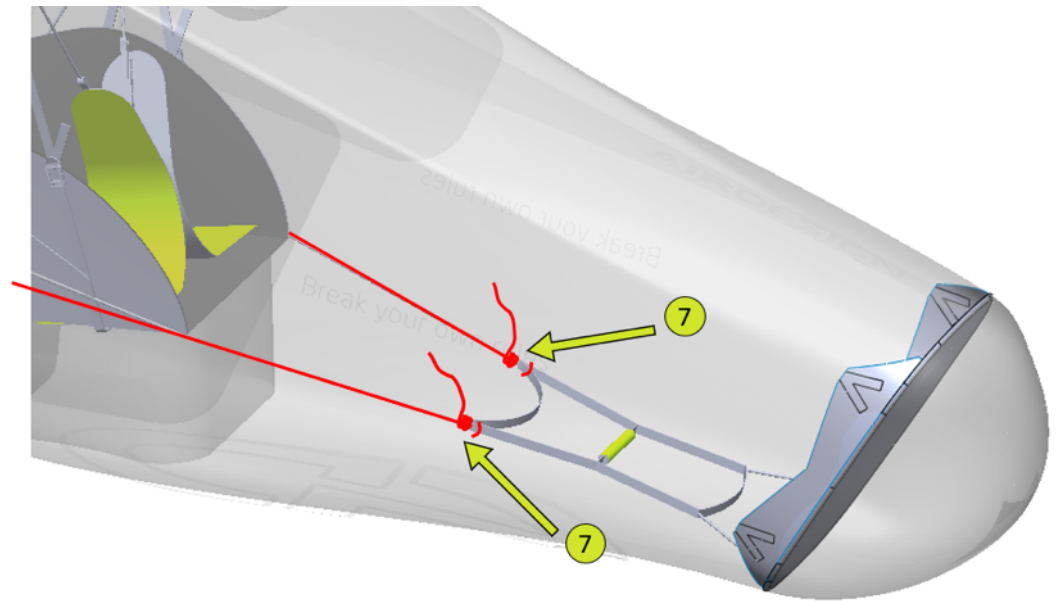

Balance Check

Check the angle of your harness and adjust if necessary.

Use back adjustments and foot plate lines to adjust legs length and harness horizontal balance.



Remark: Perform all adjustments with shoes on and all your gear in flight configuration (Weight distribution matters)

In flight Adjustment

You can adjust Back and Shoulders during the flight, but we recommend you to do it before take-off.

Enjoy your flight!



PREPARING YOUR HARNESS (details)

Connection detail (Harness- Carabiner assembly)

The harness is delivered with Carabiners. In case you have to remove them, please respect the mounting as here below.

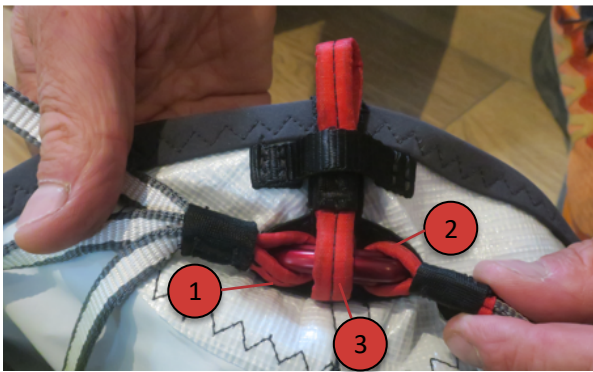

Rescue installation

Risers' connection

To connect your rescue to the risers, please proceed as shown here below.

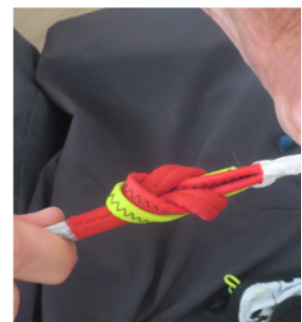

If your rescue does not allow this lark's head knot assembly, you can use a maillon with suitable resistance. Follow then the instructions related to your rescue or ask a flight instructor or professional with experience in paraglider rescue installation. By any mean, avoid friction with unsheathed Dyneema lines or ropes.

Rescue handle connection



Container closing



Risers' sleeve

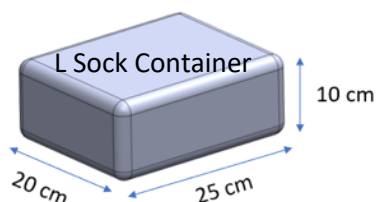

Maximum recommended volume for the rescue is 4L for S Size, 4.5L for M size, 5L for L size.

Rescue deployment

We recommend a rescue pull out at least once a year and at every repacking in order to verify its proper functioning.



Warning : User must check that the length between the handle and the container does not allow entanglement with the rescue lines.

Harness packing



COMPOSITION, CARE AND MAINTENANCE

The durability of this harness depends on your good care. Using the harness for ground handling, touch and go, speed flying or speed riding will lower its life span.

The harness is composed of Ripstop Nylon fabric, nylon elasthan fabric EVA foam, polyester mesh, polyester, Dyneema and nylon webbings, Nitinol rods, Aluminium toggles and carabiners, TPU inflatable bag with PVC pipe, zippers and polypropylene buckles.

Take care of the following:

- Avoid excessive exposure to UV, heat and humidity.
- Pack the harness dry and store in a cool dry place.
- Do not pack it too tight to avoid permanent damages to the Nitinol rods.
- Never drag or skim your harness along the ground.
- Keep you harness clean of dirt, oils and any corrosive substance.
- This harness can be washed with a soft brush and clear water. Do not dry under direct sun exposure.

ROUTINE INSPECTION

Regularly inspect your harness (every 20 flights or 3 months) by visually check the stitching, webbing and all structurally important areas. Pay particular attention to the webbing around the hang point area. Same intervals apply for your rescue / harness connections and for Air Pillow's tightness when inflated.

If you find any damage or if you are in any doubt make sure the harness is checked by a professional or contact your dealer immediately.

Harness should be checked and inspected thoroughly by a professional before reaching 5 years or 500 flights.

Change the aluminum carabiners after 5 years or 500 flights.

Warning! Do not use the carabiners if any sign of damage is visible or if they have been used in a wrong way (lateral load for example) on a previous flight, or if they have suffered from a shock.

PRODUCT REGISTRATION AND GUARANTEE

This product is guaranteed 2 years from date of purchase against production faults

Product registration – Produktregistrierung - Enregistrement de produit

Model/Modell/Modèle: The Sock

Size/Größe/Taille: S M L

Serial Number/Seriennummer/Numéro de série: _____

Date of Purchase/Kaufdatum/Date d'achat: _____

First Flight/Erstflug/Date de premier vol: _____

Customer/Käufer/Client:

Family Name/ Nachname/Nom de famille: _____

First Name/Vorname/Prénom: _____

Address/Adresse/Adresse: _____

Tel: _____

Fax: _____

Email: _____

Product Registration: cut off and send to AIRDESIGN, or register online at: www.ad-gliders.com

Produktregistrierung abtrennen und einschicken, oder online registrieren unter: www.ad-gliders.com

Enregistrement produit : couper et envoyer à AIRDESIGN, ou enregistrer en ligne sur : www.ad-gliders.com

AIRDESIGN GmbH | Rhombergstraße 9, 3.Stock | 6067 Absam | AUSTRIA

RESPECTING NATURE AND ENVIRONMENT

Finally, we would ask each pilot to take care of nature and our environment. Respect nature and the environment at all times but most particularly at take-off and landing places.

Respect others and paraglide in harmony with nature.

Do not leave marked tracks and do not leave rubbish behind.

Do not make unnecessary noise and respect sensitive biological areas.

The materials used on the harness should be recycled.

Please send old AIRDESIGN harnesses back to AIRDESIGN offices. We will undertake to recycle the harness.

Thank you, now put your Sock on, go out and enjoy your flights!