



PEPPER CROSSLIGHT

lightweight rescue chute – LTF NFL II 91/09 | EN 12491:2001

SYLVANIA

MANUAL/SERVICE 03/2017

Rev. 01 | 23.03.2017

SERIALNO.:

ENGLISH

TABLE OF CONTENT

1	Introduction	25
2	Description	26
3	Technical Data	27
4	Materials	27
5	Releasing the Rescue System	27
6	Operating limits	28
7	Packing Manual	28
8	Compatibility Test	38
9	Connect the reserve chute to the harness	38
10	Maintenance	39
11	Care	39
12	Repair	39
13	Construction	40
14	Proof of packing	41



1 INTRODUCTION

Welcome to skywalk!

Congratulations on the purchase of your new PEPPER CROSS LIGHT and thank you for your trust in us and in our products. In this manual you will find packing instructions as well as a lot of information about the correct use of the reserve chute.

At skywalk we are enthusiastic about wind sports and innovative technologies. When we founded skywalk in 2001, our goal was to make paragliders and kites that offer new solutions to set new impulses, and to provide customers with a maximum of user friendliness. Today we are one of the most successful paraglider manufacturers in the world. For this we are thankful for our curiosity about everything that flies, sails and surfs, as well as our interest in a variety of outdoor sports. It's this "big picture" view that allows us to continuously set new accents in paragliding.

We are always open for questions, comments or critique and are happy to provide you at any time with further information!

Your skywalk Team

pure passion for flying

2 DESCRIPTION

The skywalk PEPPER CROSS LIGHT is characterized by high reliability and strength, fast opening time with low sink rate, high pendulum stability, low weight and small packing volume. Its symmetrical design reduces drift to a minimum, directional flight is not specified. The PEPPER CROSS LIGHT reserve chutes are cross-cap centerline reserve chutes with retracted apex and divided panels. Optimized layout and differentiated air permeability due to special processing and material mix result in a reserve chute of the most modern design. Robust materials guarantee that the reserve chute stays in top-notch shape for many years.

IMPORTANT SAFETY WARNING

THE PURCHASER OF THIS PRODUCT ASSUMES SOLE RESPONSIBILITY FOR ALL RISKS ASSOCIATED WITH PARAGLIDING, INCLUDING INJURY AND DEATH. IMPROPER USE OR ABUSE SIGNIFICANTLY INCREASES THIS RISK. THE PURCHASER IS AWARE THAT A PREREQUISITE FOR PARAGLIDING IS A COMPLETED TRAINING COURSE AS WELL AS THE LICENSE REQUIRED FOR THE RESPECTIVE COUNTRY. ANY UNAUTHORIZED MODIFICATION OF THIS RESERVE CHUTE WILL RESULT IN THE INVALIDATION OF THE TYPE APPROVAL.



3 TECHNICAL DATA

Size	90	110	135
Area (m ²)	26,9	32,5	40,1
Number of panels	20	20	24
Line length (mm)	4100	4400	4900
Center line length (mm)	3930	4280	4500
Weight (g)	990	1140	1440
Sink Rate (m/s)	5,2	5,2	5,2
Maximum load (kg)	90	110	135
Nr. of EN-certification	EP 147.2016	EP 170.2017	EP 171.2017
Packing volume (l)	3,8	4,2	5,6
Total system height (mm)	5486	5911	6490

4 MATERIALS

Sail: NYLON 22D ripstop
 Lines: LIROS DC201, Rettungsleine 1628/29
 Webbing: GÜTH & WOLF
 Rubber bands: Silicone
 Main suspension riser: Liros D-PRO 5mm

5 RELEASING THE RESCUE SYSTEM

The PEPPER CROSS LIGHT is a reserve chute for paragliding and is only approved for this purpose. Use the reserve chute only in an emergency! To deploy the reserve chute, follow these steps:

- Pull the rescue handle firmly. The outer container opens up and the pilot is now holding the rescue system still packed in the inner container.
- Throw the container into free airspace with a hefty swing. The more powerful the throw, the faster the lines of the reserve chute will extend and accelerate the opening process.
- Immediately after the reserve chute opens, draw the paraglider in toward you to avoid the two canopies forming a V-position. This is best done via a B-line or C-line stall, by pulling down both brake lines until the glider stalls, or by pulling down one of the risers and/or several middle lines.

- Before you land, assume an upright position, put your legs together, bend your knees slightly and prepare to do a parachute landing fall.
- After landing in strong winds, pull the canopy toward you using the middle lines to keep the reserve chute from inflating again.

TIP: POORLY MAINTAINED RESERVE CHUTES MAY OPEN MORE SLOWLY. IF THIS IS THE CASE, PULL FIRMLY AND SHARPLY ON THE LINES!

ATTENTION

THE RESCUE SYSTEM MUST ALWAYS BE THROWN ON THE SIDE WHERE THE CONNECTING LINES OF THE HARNESS ARE LOCATED.

6 OPERATING LIMITS

- The PEPPER CROSS LIGHT has been specially developed for use as a reserve chute for paragliding. Any use for other flying sports such as parachuting, base-jumping etc. is prohibited.
- According to EN 12491, the reserve chute may only be used up to maximum speeds of 32 m/s or 115 km/h..
- The reserve chute must be aired out and repacked every 6 months.
- After a deployment, the reserve chute must be inspected by the manufacturer or an authorized maintenance shop for rescue equipment.
- The reserve chute must be replaced after 10 years, even if it has never been used.

7 PACKING MANUAL

All skywalk PEPPER CROSS LIGHT paraglider reserve chutes are inspected and packed in skywalk's manufacturing facility. It is recommended that the reserve chute be repacked once again by a suitably qualified and experienced specialist before installation in the harness. The effectiveness of the reserve chute and its ability to save lives depend on proper packing. If in doubt, or if you have any questions, please contact your flight instructor or skywalk dealer.

PREPARATION

- The reserve chute must be subjected to visual inspection and checked for damage to the canopy, the lines and the main riser.
- Before repacking, the reserve chute must be aired out, ideally for 12 hours in a cool, dry room.
- The packing area must be large enough, clean, level and dry.



Step 1 & 2

Use a piece of line to thread the packing loops together. Don't forget the four corner loops mounted slightly further back on the panels. Secure the packing loops for now and pull on the main riser and the attached loops until it is tight.





Step 3

The PEPPER CROSSLIGHT is a cruciform rescue parachute with four corner points, so lay out the canopy with one corner at the bottom, one on the left, one on the right, and one on top. Start with the first corner at the bottom and smooth the material by running your hand along it on the table.



Step 5

Now lay out the next panels in a rectangular fashion. They will be slightly easier to lay.



Step 4

Pull the base from one line attachment point to the next along the seam to the side you are sorting and smooth the crossed panel. A line separator and a weight will help secure the already sorted lines.



Step 6

Now comes the corner that points to one of the sides. This is also to be laid out in a crossed fashion, as in the picture.



Step 7

Next, you will again encounter rectangular panels until you reach the next corner, which is now the uppermost and last one on this side. Make sure that you leave a channel through which you can see the table underneath. We will come to this later.



Step 9 & 10

Now return to the canal and run your hands along the connecting points of the middle lines until they are free of the material. The extra material simply can be pushed up inside the canal as in the picture. The reason for this is to prevent the material from burning during a deployment.



Step 8

Now repeat steps 4 to 7 for the second side.





Step 11 & 12

You are done with the sorting of the panels, so now you can inspect the middle lines towards the main riser to see if the middle line are free.

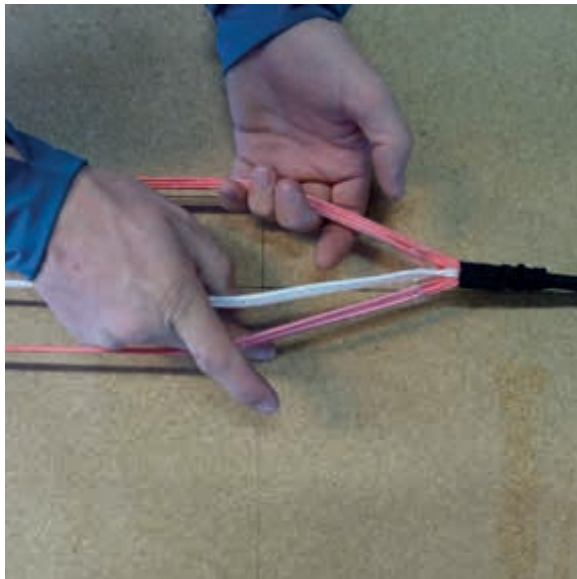

Step 13

Now fold the reserve chute with a „double-S fold“ and place the reserve container with the line pocket in the direction of the base/main riser.

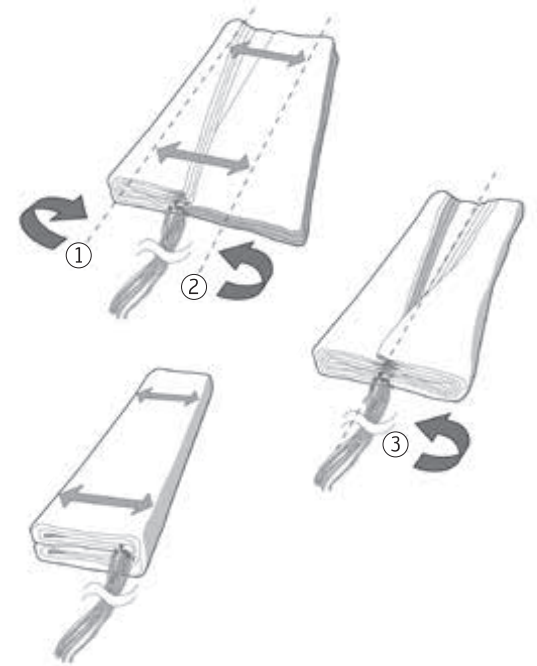

Step 14

Now place the reserve chute like a snake in the container, taking care to use the full length and width.



Step 15

Now close the first three rescue flaps and secure them with a small line loop. This method will avoid burns from a deployment later since the bundle of lines will be released first and will not come in contact with the material.



Step 17

Now place the line bundles in the designated line pocket inside the reserve container.



Step 16

Starting at the main riser, loop the line bundles in the shape of a figure-eight. Make sure to leave approx. 40 cm free to the first figure-eight. This length is needed for the final line loop.



Step 18

Secure the fourth and final rescue flap with the remaining line length from step 16.

The Rescue system is now packed !

8 COMPATIBILITY TEST

The PEPPER CROSS LIGHT rescue system is appropriate for integrated reserve chute containers. The first time installation of the Reserve chute into the harness should be carried out only by an expert, a so-called compatibility-testing authority. This requirement is necessary to make sure that no unsuitable harnesses with integrated outer containers are used in combination with our reserve. Please contact your flight school or skywalk dealer to prepare for the initial installation. There you can find in most cases a certified compatibility tester.

ATTENTION

AFTER EVERY REPACKING AND REINSTALLATION OF THE RESERVE CHUTE IN THE OUTER CONTAINER, THE CORRECT OPENING OF THE OUTER CONTAINER MUST BE CHECKED WITH THE PILOT SITTING IN FLIGHT POSITION, PULLING ON THE RESCUE HANDLE AND ENSURING THAT THE OUTER CONTAINER OPENS SMOOTHLY, THE RESERVE CHUTE IS HANGING ON THE RESCUE HANDLE, AND IS PROPERLY CONNECTED TO THE HARNESS. THE PULLING FORCE OF THE RELEASE HANDLE MUST BE BETWEEN 4 AND 8 DAN.

9 CONNECT THE RESEVE CHUTE TO THE HARNESS

The main riser of the reserve chute is connected to the V-lines of the harness by a suitable steel screw shackle. It is important to ensure that the connection is centered, that is, the two connecting lines leading to the shoulder straps are of the same length. If the harness does not have an integrated attachment possibility for the reserve chute on the shoulder straps, then the reserve chute connecting line can also be attached to both main carabiners.

CAUTION

THE LINK SHOULD HAVE A MINIMUM BREAKING LOAD OF 2400 DAN, AND THE CONNECTING LINES SHOULD BE SECURED TO THE CONNECTING LINK WITH A RUBBER RING, A NEOPRENE GUARD OR A FIXING TAPE TO PREVENT WEAR AND SLIPPING.

10 MAINTENANCE

The skywalk PEPPER CROSS LIGHT rescue should be repacked at least every 6 months, as detailed in the packing instructions. We always recommend that this rescue parachute is inspected and repacked by a trained professional repacker. Additional inspections should be performed if there is any suspicion of damage or undue wear. Always seek professional advice whenever in doubt. The materials used in the rescue have been carefully selected for maximum durability. Nevertheless, maintaining your rescue following the guidelines below will extend its lifetime. It is recommended that a rescue is replaced after 10 years, even if it has never been used.

11 CARE

- Avoid direct sunlight with the associated UV exposure, as well as heat and moisture.
- Store your harness and rescue equipment in your rucksack when you are not using it.
- Keep your paraglider equipment in a cool, dry place and not near solvents, greases, acids, oil and paints.
- Always dry your reserve chute if it gets wet in a well-ventilated, shady place.
- If the reserve chute comes in contact with salt water, rinse it several times with fresh water.
- A soiled reserve chute can be cleaned with lukewarm water. If necessary, mild neutral soap can be used, but do not rub the material too much.
- If the material has stains or mold, it must be sent to the manufacturer for inspection and possible repairs, or to an approved maintenance facility for rescue equipment as the strength may be impaired.
- If the reserve chute has to be stored for a long time, then it is best to store it open and loosely rolled up.

12 REPAIRS

Any repairs should only be carried out by the manufacturer or by an approved agent. This will ensure that the correct materials and repair techniques are used.

NOTES

NOTES

Skywalk GmbH & Co. KG

Windeckstr. 4 | 83250 Marquartstein | +49 (0) 8641/69 48 40 | info@skywalk.info | www.skywalk.info

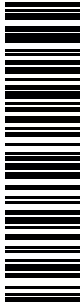

SAMAPC100